

**N4YG**

**Direct Digital  
Synthesis System**

**Drake TR-7/RV-7  
Installation  
&  
Users Manual**

## TR-7/RV-7 DDS Installation

The following is a step-by-step process for installing the N4YG DDS system into the Drake TR-7 or RV-7. The pictorial on the third page of this document along with the steps below allows a systematic approach which should be comfortable for the average radio amateur.

1. Remove the PTO. Be sure to mark or document where and what color the wires go and their functions, including power input and PTO output. The DDS output will have to be connected where the PTO output was connected.
2. Mount the incremental encoder on the front panel. The hole in the front panel is too large. AD3G removed the plastic escutcheon from the front panel and sandwiched piece of sheet metal (1-1/2 inches square) between the escutcheon and the front panel. A hole was drilled in the sheet metal to accommodate the incremental encoder. The sheet metal should be thin, about .050 inches thick. Otherwise when the escutcheon would be raised when it is replaced.
3. Mount or select and prepare existing pushbutton switches for DDS Control and LOCK.
4. Mount or select and prepare an existing potentiometer (1 to 20 K ohms) the RIT potentiometer.
5. Mount any or all LEDs for VFO A, VFO B, SPLIT, LOCK and RIT.
6. Five (5) 150 Ohm resistors (Brown-Green-Brown) are provided. One lead of each of these must be connected to the anodes of the 5 LEDs, if these are used. The anode is the longest lead of the LED. After the 5 resistors are connected to the LEDs, the remaining loose leads are connected together. These will be connected to the wire coming from J2, pin 7 later.
7. Select the location for mounting the DDS board. There is ample room in the RV-7 however it is a bit more difficult in the TR-7. Use standoffs to mount the board.
8. Refer to the pictorial on the next page while completing the next several steps.
9. Connect the power cable connected to J6 to any +8 to +13 VDC source capable of supplying 200 mA of current. Pin 1 is the input pin and Pin 2 is ground.
10. Connect the DDS output to the same point where the PTO output was connected. In the RV-7 there is a small PC board which must remain. The DDS output connects to the top pin nearest the rear of the RV-7. The braid ground connects to the bottom pin nearest the rear of the RV-7.
11. In the RV-7, the cable from the TR-7 supplies 13.6 VDC to vfo output signal to RV-7 through a small choke. When this voltage is on, a pin diode on the TR-7 translator allows the output to pass to the TR-7.
12. There are 8 wires coming from J1 which must be connected to points within the TR-7. Refer to the pictorial.

- a. Pin 1 goes to the ungrounded lead of the DDS Control (DCON) pushbutton switch. The other lead of the switch must be grounded. Any convenient ground may be selected. One source is lug A of the RIT pot which is grounded.
  - b. Pin 2 goes to the cathode of the VFO A LED.
  - c. Pin 3 goes to the cathode of the VFO B LED.
  - d. Pin 4 goes to the ungrounded lead of the LOCK pushbutton switch. The other lead of the LOCK switch (like the DCON switch) must be grounded.
  - e. Pin 5 is a ground source which is connected to lug A of the RIT pot.
  - f. Pin 6 must be connected to the Transmit/Receive (TR) voltage which is approximately 10 volts during transmit and 0 during receive. This is required if SPLIT and/or RIT capability is used. If neither is used, this wire should be connected to ground if not connected to the TR voltage.
  - g. Pin 7 goes to the center lug (B) of the RIT pot.
  - h. Pin 8 goes to the cathode of the SPLIT LED.
13. J2 has only one wire to be attached. Connect the wire coming from pin 7 of J2 to through the supplied 330 ohm resistor to lug C of the RIT pot, that is, one lead of the resistor connects to lug C and the other lead to the wire coming from pin 7.
14. Three wires coming from J3 must be connected to points in the TR-7:
- a. Pin 1 connects to the ends of the 5 150 ohm resistor which are all connected together. See Step 6.
  - b. Pin 2 connects to the cathode of the LOCK LED.
  - c. Pin 3 connects to the cathode of the RIT LED.
15. Plug J2 into JP2 on the DDS board, making sure that pin 1 of J2 is aligned with the pin 1 dot near JP2. Plug the other end of the cable, J4, into the incremental encoder, making sure that the +, -, A and B marking are matched with those on J4.
16. Plug J6 into JP6 on the DDS board.
17. Apply power, check for RF output (listen to the receiver) and adjust the output to the proper level by adjusting trimmer R8. The output should be adjusted to the minimum level which gives stable full performance.

# N4YG DDS System Pictorial

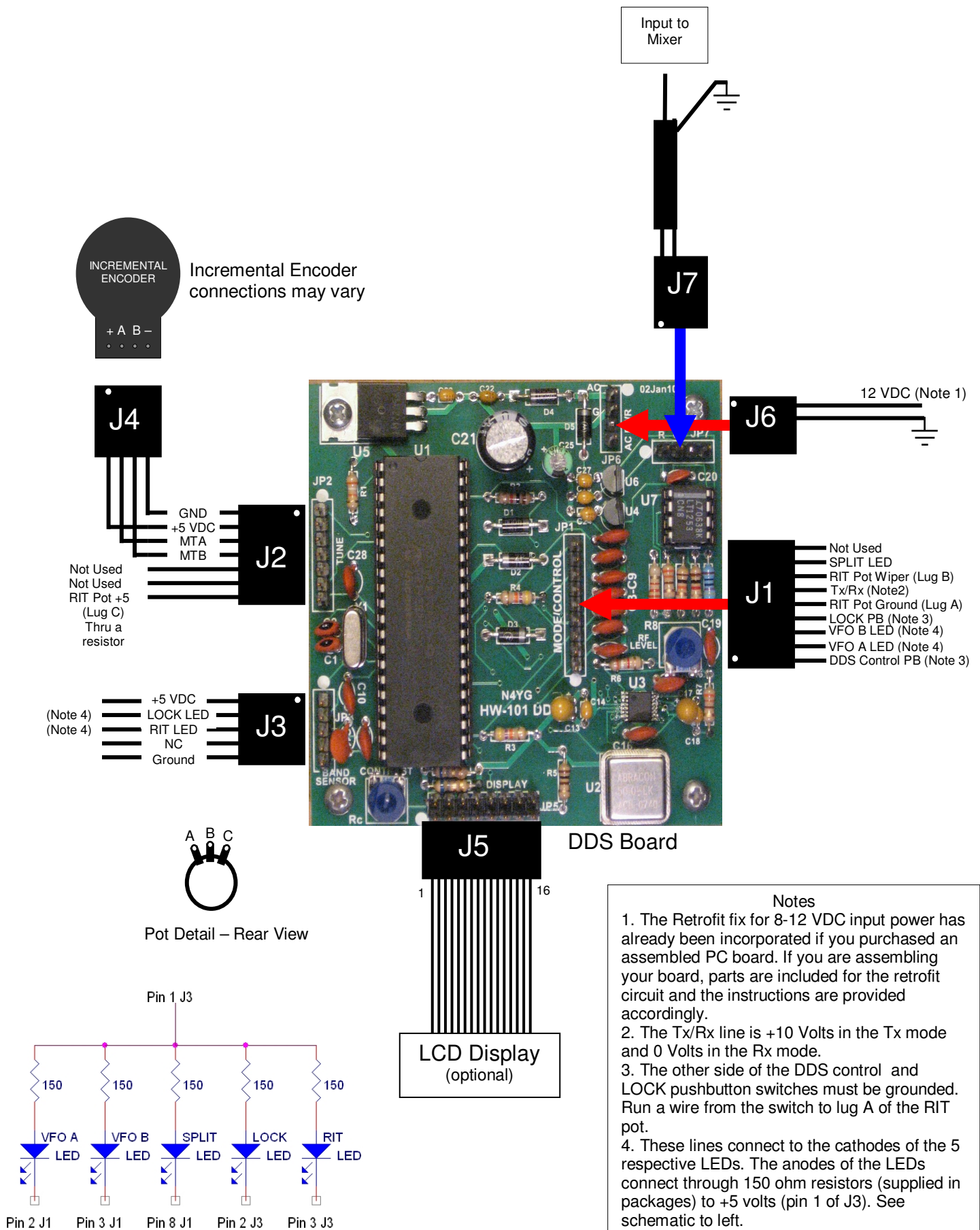

# Operating the DDS System

## 1. Controls

The only controls are the Main Tuning control (which rotates the incremental encoder), the DDS control pushbutton, the RIT control and the LOCK pushbutton

- Main Tuning Control  
The Main Tuning control rotates the shaft of the incremental encoder. When the shaft is rotated, pulses are generated by the encoder and sent to the processor on the DDS board. The processor code implements variable tuning rate. Variable tuning rate is used so that very slow tuning rates can be used for fine tuning and high tuning rates can be used to tune rapidly across the band. Measured in Hz per revolution, the tuning rate is 256 Hz per revolution for very slow rotation and up to about 100 KHz for a very fast rotation of the Main Tuning control. At a comfortable rotation rate of about one rotation in 3 to 5 seconds, the tuning rate is about 2 to 3 KHz per revolution.
  
- DDS Control Pushbutton  
The DDS Control pushbutton controls the operation of the two VFOs. In very simplified terms, there are two numbers in memory which define the frequencies of the two VFOs, VFO A and VFO B. Either A or B may be designated for Rx and either may be designated for Tx. If the Rx and Tx VFO designations are different then the SPLIT mode is in effect. When first turned on, the values for VFO A and VFO B are given the values stored in memory and the Rx VFO and Tx VFO will be VFO A. Let us say for example that VFO A is set at 5.3579 and VFO B is set at 5.2222. When you turn it on, you will see one of the frequencies. For 40 meters for example, "7357.9 KHz" would be displayed if VFO A is the current VFO. If you "Single-Click" the button as you would single click a mouse, the VFO B frequency appears. Do it again and the VFO A value appears on the display. In addition to the "Single-Click", you may also "Double-Click", "Long-Click" and "Very-Long-Click". The "Double-Click" is again like double clicking with a mouse. The "Long-Click" is a pushbutton closure lasting more than about a second. The "Very-Long-Click" is a closure lasting about 2 seconds or more. Each time you do any of these, the values for VFO A and VFO B are saved to flash memory and the following also occurs:
  - "Single-Click" complements both Rx and Tx VFOs.

- "Double-Click" complements the Tx VFO. This effectively toggles between SPLIT and UNSPLIT
- "Long-Click" equates VFOs to the value of the Rx VFO.
- "Very-Long-Click" no action other than to save current values

When the unit is turned off and then back on again, VFOs A and B will have the values as when they were last saved.

- LOCK Pushbutton

Each time the LOCK pushbutton is pressed, the LOCK condition toggled. The LOCK LED will be on anytime the DDS system is locked.

- RIT Control

The RIT control provides an offset between your transmit and receive frequencies. At the center of the rotation of the pot, there is a small deadband where rotation of the control causes no change in frequency. When the RIT control is rotated to this central deadband, the RIT LED will be turned off, indicating that RIT is not active. Outside the deadband where there is a non-zero value of incremental tuning, the RIT LED will be illuminated. To either side of the deadband a maximum of +/- 1500 Hz tuning of the receive frequency is available.

## 2. Indicator LEDs

The five indicator LEDs are referred to as VFO A, VFO B, SPLIT, LOCK and RIT. When the TR-7 is first turned on VFO A will be the Rx and also the Tx VFO. The SPLIT LED will be on any time that the Tx and Rx VFOs are not the same. Thus only the SPLIT LED will be off initially. If you "Click" the DDS Control button, the VFO A LED will go off and the VFO B LED will come on. Click again and VFO A is on. Each time you Click the lighted LED will switch between A and B. If you transmit, there is no change because the Rx and Tx VFOs are the same. If you Double-Click, you will see the SPLIT LED come on. If you transmit while in the SPLIT mode, you will see one (A or B) come on and the other go off.

The LOCK LED comes on when the DDS system is locked. When locked, the DDS is stopped in its tracks and none of the controls (except the LOCK pushbutton) are functional. Each time the LOCK pushbutton is pressed, the LOCK condition is toggled.

The purpose of the RIT LED is to indicate a non-zero incremental tuning value. Whenever the RIT LED is illuminated the operator should be reminded that the Transmit and Receive frequencies are not the same.

## Technical Information

The N4YG DDS system contains a power supply, a microcontroller chip, a direct digital synthesis chip and an output amplifier. The microcontroller provides an interface for a liquid crystal display (LCD) which is optional and normally not required with the TR-7. The system provides an RF output frequency in the range from a fraction of a Hz to over 15 MHz. The output of this particular unit is limited to a range of approximately 750 KHz. The general specifications are shown below.

Frequency Range	4900 to 5650	KHz
Short-Term Stability(typical)	1	Hz
Long-Term Stability(typical)	less than 50	Hz
RF Output Voltage	0 to 20	Volts Peak-To-Peak
Frequency Resolution	0.0116	Hz
Tuning Input	Optical Incremental Encoder (128 Pulses/Revolution)	
Frequency Update Time	~100	microseconds
Spurious Output	60 dB or more below primary output	
Power Requirements	8-18 VDC @ approximately 200 mA	

The power supply was originally designed to operate from an input of 12.6 VAC. A small modification consisting of 2 resistors and a capacitor has been added and several components are removed in order to use a DC input voltage, 8 to 18 VDC.

The 16F877A microcontroller controls all the processes on the board. The various inputs include:

- Incremental encoder
- DDS Control Pushbutton Switch
- Transmit/Receive Logic Line
- RIT Tuning Voltage
- LOCK Pushbutton Switch

With these inputs, the microcontroller continually tracks all frequency and mode changes and provides data to the AD9835 DDS processor regularly update its output frequency. Data is provided at the LCD interface port which will display VFO frequencies and other information if a LCD is connected to the port. The RF output from the DDS processor is less than 300 millivolts, which is insufficient to drive the TR-7 mixer. The output amplifier can provides more than enough drive and is continuously adjustable. Generally the output is adjusted to the minimum level required for full, reliable performance.

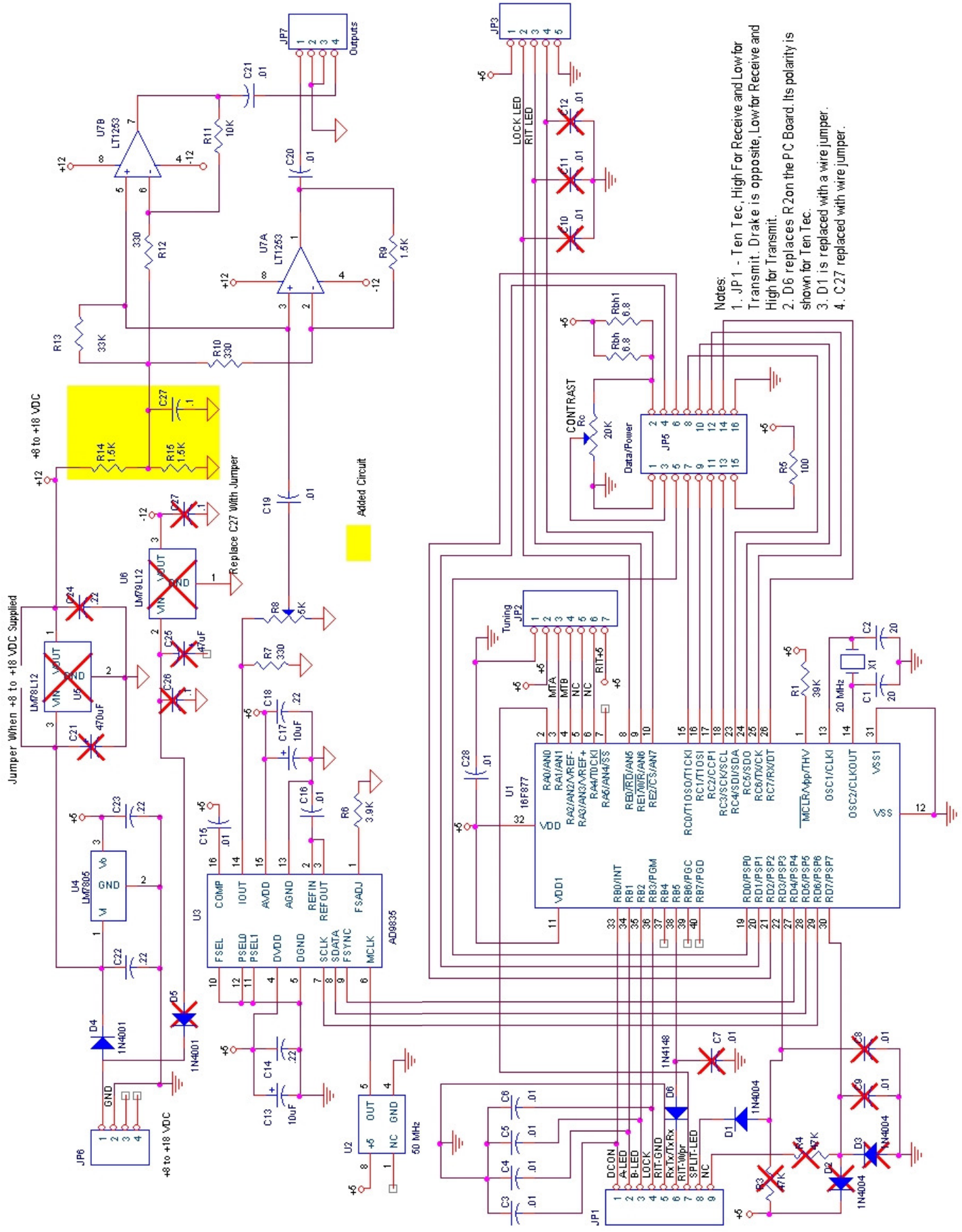

- Notes:
1. JP1 - Ten Tec, High For Receive and Low for Transmit. Drake is opposite, Low for Receive and High for Transmit.
  2. D6 replaces R2 on the PC Board. Its polarity is shown for Ten Tec.
  3. D1 is replaced with a wire jumper.
  4. C27 replaced with wire jumper.

Jumper: When +8 to +18 VDC Supplied

Added Circuit